

2 WAY 2 POSITION ELECTRIC POPPET VALVE, PILOT OPERATED NC

- Flow **60 l/min**
- Max working pressure **350 bar**
- Leakage **0,25 cc/min**
- Seals **NBR and PTFE**
- Cartridge tightening torque **40 Nm**
- Ring nut tightening torque **5 Nm**
- Weight (with coil)..... **0,56 Kg**
- Cavity **C230000** page 210
- Body..... **171302** page 191
- Coil (to be ordered separately) **09801** page 181

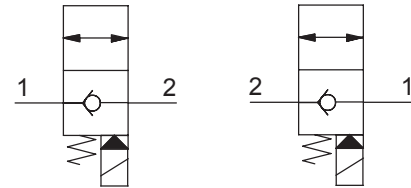

Scheme 0

Scheme 1

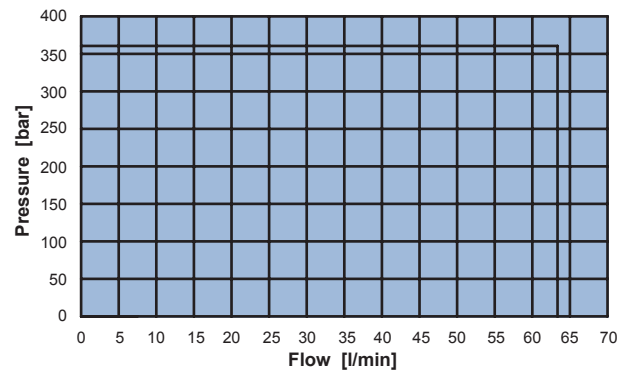
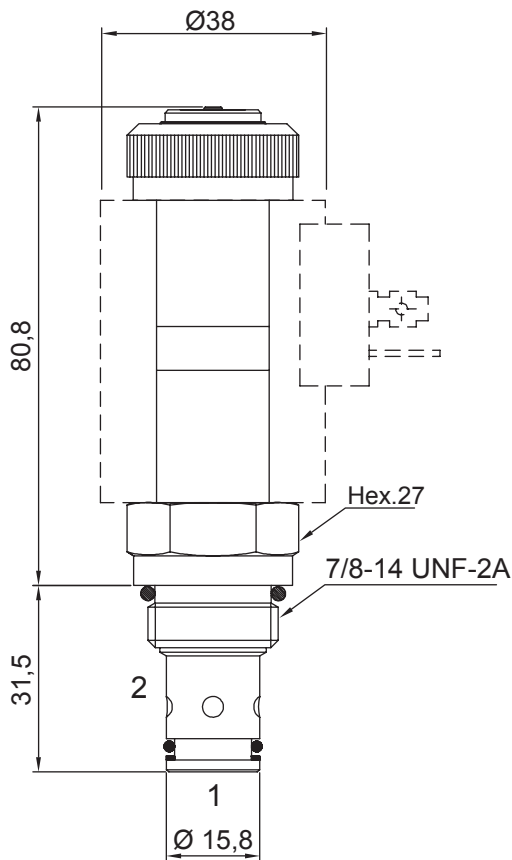

Application limits from 2 to 1 and 1 to 2

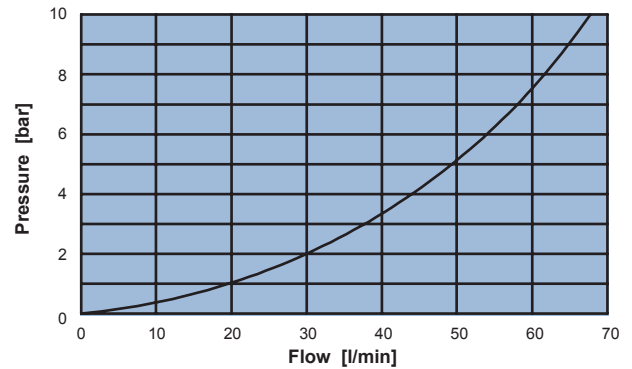

Pressure drop from 2 to 1 and from 1 to 2

Ordering code

0 5 6 3 1 0 0 0

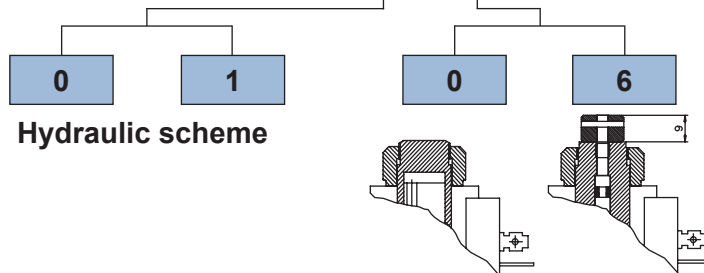

No emergency Unscrew type

