

HYDR. VORGESTEUERTES DOPPEL RÜCKSCHLAGVENTIL

- Nenn Volumenstrom (Q) **30 l/min**
- Max Arbeitsdruck (P) **350 bar**
- Arbeitsdruck (P) **210 bar (Aluminium Gehäuse)**
- Arbeitsdruck (P) **350 bar (Stahl Gehäuse)**
- Gewicht in Stahl **0,9 Kg**
- Gewicht in Aluminium **0,64 Kg**

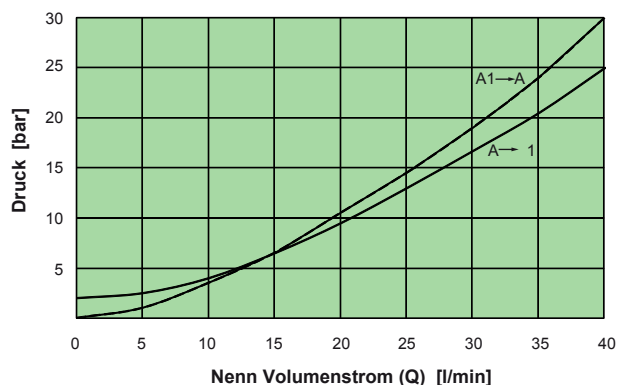
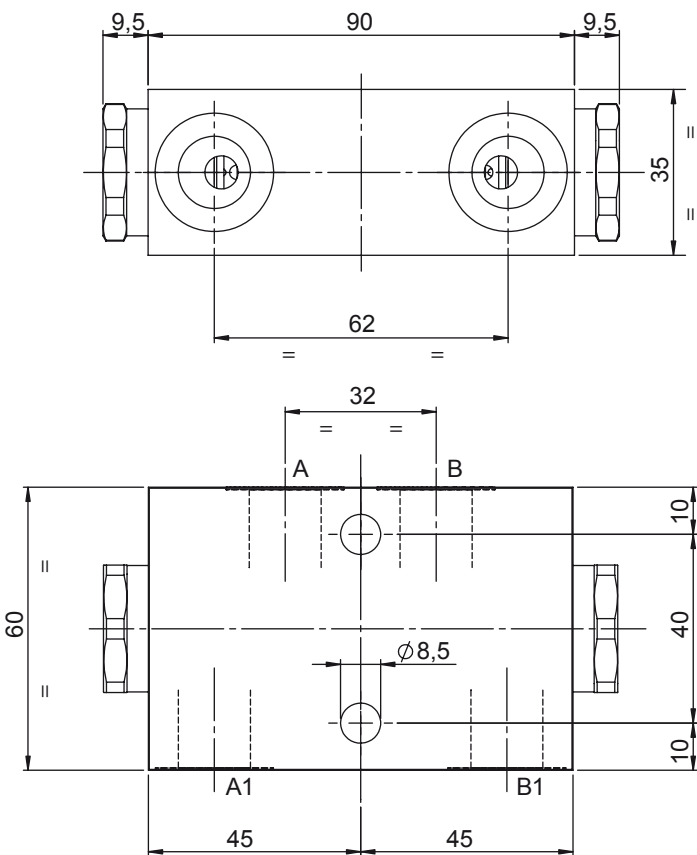
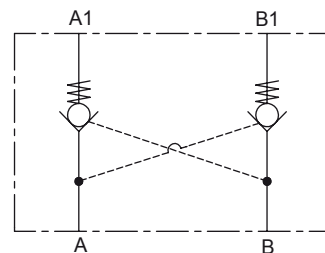

Typenschlüssel

D 0 4 1 0 0 0 0

Aufsteuerverhältnis		Federn		Material		Anschlüsse	
7	7:1	02		A		03	
		Einstellung		Aluminium		A,A1,B,B1	
		Dichtungen		Stahl		G 3/8"	
		ohne				SAE 6	
						a	
						b	
						32	
						62	
						31	
						63	