

Standard working conditions	
Max inlet flow	50 l/min
Max input pressure	350 bar
Max back pressure (T line)	20 bar
Operating temperature range	-20°C / +80°C
Kinematic viscosity range	10-300 Cst
Port dimensions	
Tank port T	G 1/2"
Inlet port P	G 1/2"
Service ports A1-A8 B1-B8	G 1/2"
Painting	RAL 9005

HYDRAULIC DIAGRAM

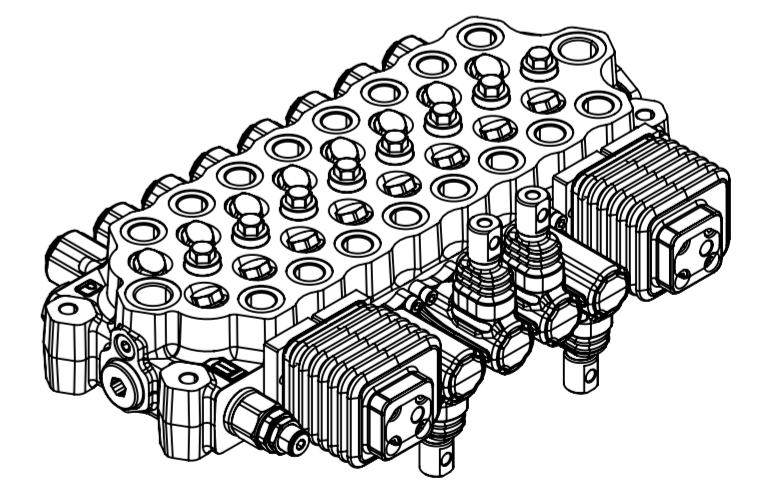
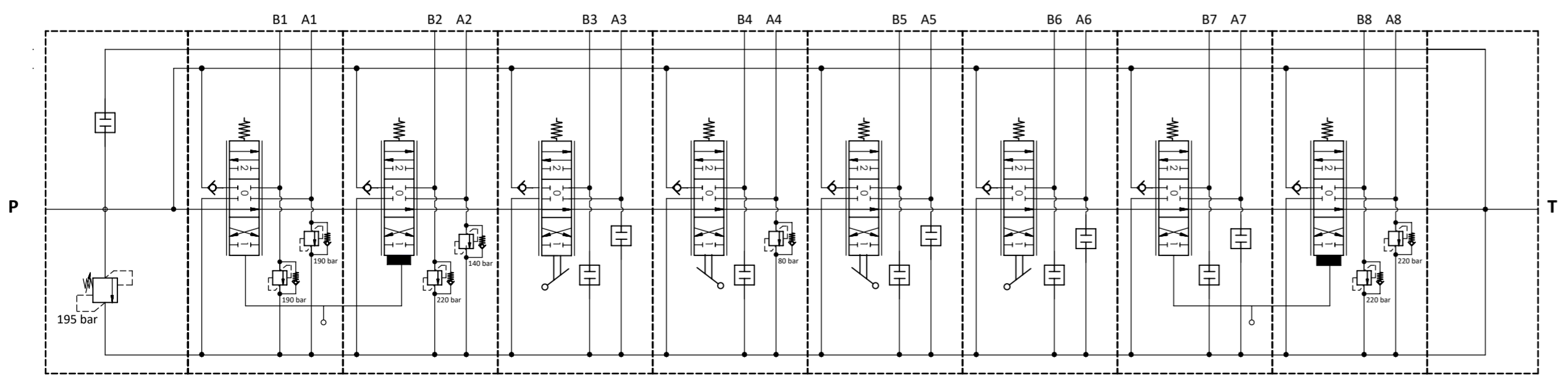

ASSEMBLY DESCRIPTION:

DER HYDRAULIKER Technik für Ideen	Scale:	1:2		Catalogue code:		
	Approved by:	MD		Group:	Prototype:	
	Designer:	RA	Date:	06/11/2023	CODE:	Part Rev.
						0

0 06/11/2023 RA FIRST RELEASE